

AURORA FIRE PUMPS

OPTION 73 - ECCENTRIC SUCTION REDUCERS OPTION 74 - CONCENTRIC DISCHARGE INCREASERS

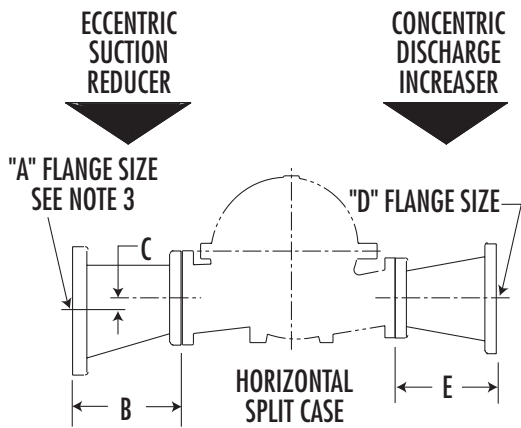

OPTION 73 ECCENTRIC SUCTION REDUCERS			
Size	A	B	C
3 x 2	3	6	.5
3 x 2-1/2	3	6	.25
4 x 3	4	7	.5
5 x 4	5	8	.5
6 x 4	6	9	1
6 x 5	6	9	.5
8 x 6	8	11	1
10 x 8	10	12	1
12 x 10	12	14	1
14 x 12	14	16	1

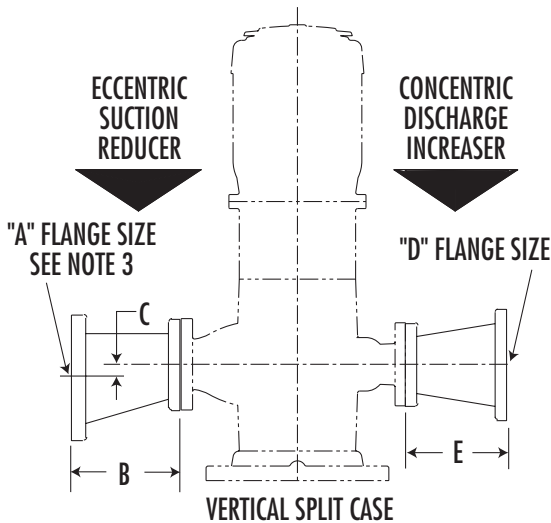

OPTION 74 CONCENTRIC DISCHARGE INCREASERS		
Size	D	E
2-1/2 x 3	3	6
3 x 5	5	8
3 x 6	6	9
4 x 5	5	8
4 x 6	6	9
5 x 6	6	9
5 x 8	8	11
6 x 8	8	11
6 x 10	10	12
8 x 10	10	12
10 x 12	12	14
10 x 14	14	16

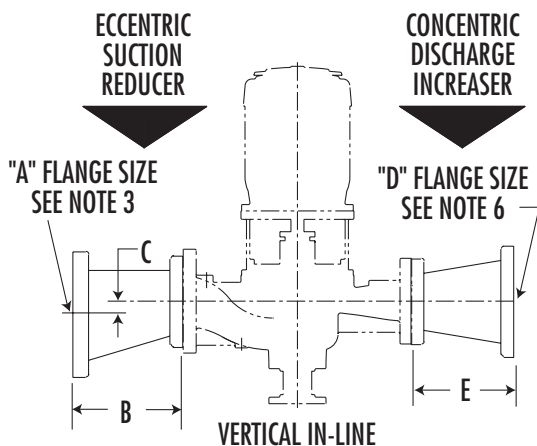

NOTES:

1. Dimensions are in inches (mm) and may vary $\pm 1/4"$.
2. Dimensions applicable to both Class 125 & Class 250 fittings.
3. Illustrations show the intended installation positions and orientation of each fitting: Eccentric Suction Reducers are to be installed with the straight side to the top to prevent air entrapment.
4. Proper pipe supports are required to prevent strain on pump casing.
5. Fittings shown are intended to adapt the fire pump suction and discharge flanges to the actual system manifold pipe sizes. Refer to NFPA 20 for the minimum system manifold size for each flow rating (GPM), but in no case should the system suction pipe be a smaller pipe size than that of the pump suction flange.
6. Refer to Section 911, Page 202 for discharge fittings tapped to accept installation of casing relief valve suitable for use with Model 383 vertical in-line fire pumps.