

FIG NO.	MATERIALS
BH-21-1	BRASS
BH-21-2	ALUMINUM

B120G

SWING CHECK VALVE

For sprinkler and standpipe systems.
Available with the following thread:
NPT Male inlet X NPT Female outlet
NPT inlet X Groove outlet
Groove inlet and outlet

1. WORKING PRESSURE = 250 LB
2. TESTING PRESSURE = 100% 125 lbs
TEST AIR/WATER
REMARK: THREADED BS 21 or ANSI B1.20.1
GROOVED TO ANSI/AWWA C606-87

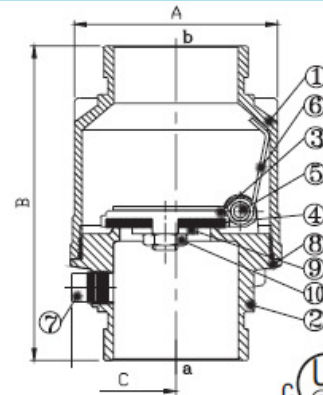

UL US
LISTED 75BM



DIMENSIONS (mm)

SIZE	FIG NO	"A"	"B"
2"	FM	80	126
	FG	80	132
	GG	80	144
2-1/2"	FM	103	154
	FG	103	154
	GG	103	164
3"	FM	118	187.5
	FG	118	182
	GG	118	189
4"	FM	138	173
	FG	138	165
	GG	138	200



FM

FG

GG

NO	NOMENCLATUR	MATERIALS	NO	NOMENCLATUR	MATERIALS
1	BODY	ASTM B584 C85700	6	SPRING	JIS G4314 SUS304-WPB
2	END PIECE	ASTM B584 C85700	7	PLUG	ASTM B 16 C36000
3	DISC	ASTM B124 C37700	8	O-RING	NBR
4	WASHER	RUBBER	9	CLAMPING WASHER	ASTM B 16 C36000
5	HINGE PIN	ASTM B16 C36000	10	CLAMPING NUT	ASTM B 16 C36000