

WORKING DIMENSIONS

Length:	5.3 m (16 ft. 5 in.)
Width:	4.3 m (14 ft. 1 in.)
Height:	3 m (9 ft. 10 in.)
Weight:	5,5 tons

INTERNATIONAL SHIPPING DIMENSIONS

Shipping Method:	One (1) containers 40'
------------------	------------------------

FLOTATION

Dimensions:	Two pontoons 4.5 m x 1 m x 1.25 m with Central Platform
Draft:	80 – 90 cm

WORKING CAPACITY

Capacity:	150 m ³ /h – 600 m ³ /h (660 gpm – 2640 gpm)
Head:	28 m – 8 m (91 ft. – 26 ft.)
Working Depth:	Up to 100 m (328 ft.)

POWER SOURCE

Type:	On-shore Electric Power Generator
Minimum required Power	130 kVA

SUBMERSIBLE DREDGE PUMP

Type:	EL60A/B/HC
Discharge Diameter:	150 mm – 250 mm (6in. – 10 in.)
Impeller Diameter:	440 mm (1 ft. 5 in.) / 3 blades, closed
Max. Solid Handling:	60 mm (2.36 in.) / 90 mm (3.5 in.)
Speed:	980 r.p.m.
Phases:	3 Phases
Frequency:	50 Hz / 60 Hz
Voltage:	On request
Insulation Class:	H
Power:	44 kW (60HP)

JET RING SYSTEM

Water capacity:	60 m ³ /h
Pressure:	6 bar – 7 bar
Drive:	On-barge horizontal high pressure pump

PROPULSION

Primary System:	Four (4) 50 m steel Winches (available up to 110 m)
Secondary System:	Helix Propeller (OPTIONAL)

ELECTRICAL SYSTEM

Voltage:	On request
----------	------------

SAFETY

Features	Completely remote controlled dredge with no operators on-board. The dredge is controlled from up to 500m away from a remote control, greatly reducing the risk to the operators.
----------	--

ANTI-CORROSION FEATURES

Includes:	Hull below deck painted with marine-grade epoxy. Hull above deck painted with polyurethane epoxy and remaining components coated with heavy-duty powder coating all suitable for salt-water service.
-----------	--

EQUIPMENT	BASIC	STANDARD	FULL OPTIONAL	HIGH DEPTH
Winches for moving	X	X	X	X
Night time operating lights	X	X	X	X
Electric Hoist	X	X	X	X
Control Panel	X	X	X	X
Temperature Sensor		X	X	X
Pond Bottom Liner Protection		X	X	X
Jet-Ring System		X	X	X
Digital Depth Gauge		X	X	X
Power Consumption gauge		X	X	X
Moisture Sensor			X	X
Dredge GPS System			X	X
Helix Propeller			X	X
Maintenance Cabin			X	
Pressure Compensator				X

ANTI-CORROSION PACKAGE AVAILABLE ON REQUEST (PH 2 – 12)

The setups in the table above are referential. The final setup for the dredges is determined upon studying the client's needs.



THE DREDGE

Jet Ring System

- On-barge horizontal, high pressure water pump
- Suction and Discharge hoses included
- Water flow: 60 m³/h
- Pressure: 6 bar – 7 bar

Electric Control Panel

- Complete Control panel
- Connection for Power cable
- Regulates pump start-up with Soft starter
- Distributes Power to all components on the dredge.

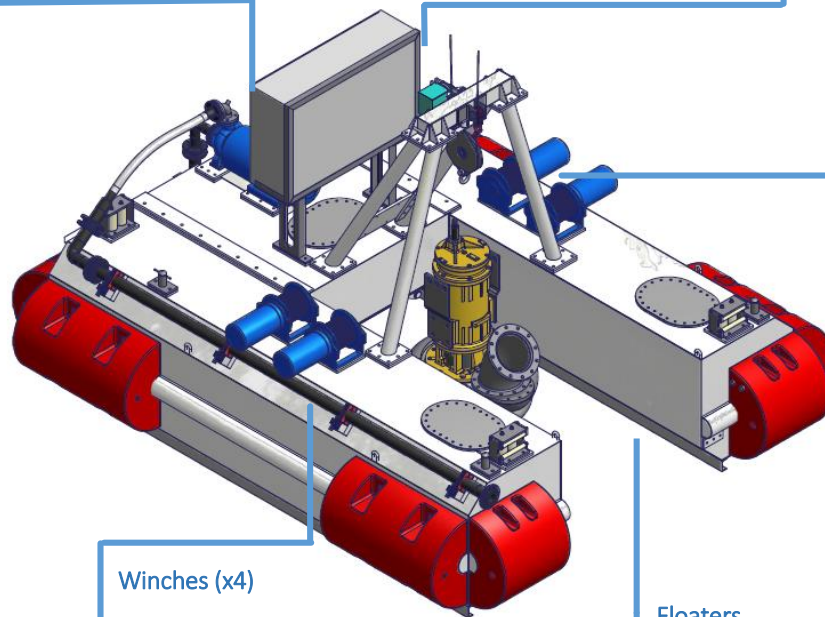

Electric Hoist

- Carefully move pump up and down
- Depth measuring pulley



Winches (x4)

- Used for moving the dredge
- Steel cables
- Optional propeller

Floater

- Two (2) pontoons 4.5 m x 1 m x 1.25 m with central platform
- Small draft



THE PUMP

Jet-Ring System

- High pressure water jets used to rupture the material and have a higher solid concentration in the mixture
- Water Capacity: 20 m³/h – 200 m³/h
- Pressure: 6 bar – 7 bar
- Drive: On-barge Horizontal high pressure pump



Pump

- Capacity: 150 m³/h – 600 m³/h
- Head: 28 -8 m
- Discharge diameter: 150mm – 250mm
- Suction diameter: 545mm
- Impeller diameter: 440 mm
- Max. solid handling: 60 – 90 mm
- Speed: 980 r.p.m.

Remote Control

- Turn pump ON/OFF
- Jet-Ring ON/OFF
- Move pump up and down
- Move dredge sideways
- Emergency stop
- Display with working depth and power consumption

